

---

# McAllister Technical Services

*Manufacturers of surface analytical instruments and devices*

---

West 280 Prairie Avenue Coeur d'Alene, Idaho 83815

Telephone: (208) 772-9527 Fax: (208) 772-3384

E-mail: [solutions@mcallister.com](mailto:solutions@mcallister.com)

## MC1500 / 2000 Instructions

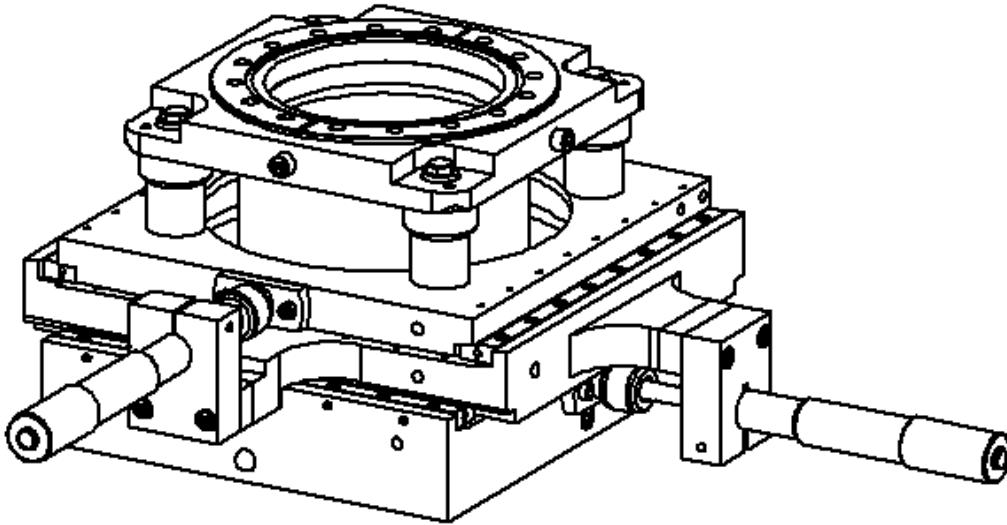

**THANK YOU** for your purchase of MTS' MC1500 / 2000 series XYZ sample manipulator. It is the finest of its kind available. We appreciate the confidence you have placed in our company. We encourage your comments and suggestions on this product and its manual. Please read this manual carefully prior to assembling/mounting your manipulator. We have found this will answer many of the commonly asked questions, saving time and aiding understanding. It will be time well spent.

### Leak Check Certificate

Model	Date	Job #	Checked by
MC__			
This is to certify that the above-referenced product has been checked on a Helium Mass Spectrometer leak detector having a sensitivity of ____ X 10 <sup>-</sup> std. cc/sec and has been found to have no measurable leak.			

### **Check for Damage:**

Many shipping companies require that claims for damage and/or loss be filed within a very short period of time, sometimes within one week of delivery! Promptly inspect the shipment for exterior as well as hidden damage. If **any** damage or loss is encountered, be sure to do **ALL** of the following:

- Notify the shipper promptly. If the damage is significant, insist on an on-site inspection.
- Retain ALL packing materials.
- Do not proceed with installation or unpacking.
- Do not allow the shipping company to remove the goods from your premises without first notifying MTS.

Verify the shipment received against the enclosed packing list and against your order. Notify MTS promptly of any discrepancies. Clean any debris, dust or stray packaging material from the manipulator before removing the flange covers. Check for any loose screws.

**Unpackaging Instructions:**

Inspect the unit for hidden damage from shipment. Translators are shipped with custom foam-in-place packing. We have found this to be the best way. The foam is separated approximately halfway inside the carton with thin white plastic. The unit is also bagged in polyethylene, and the flanges are covered with aluminum foil and plastic covers. All of this is designed to get the unit to you in the same condition it left our shop. We recommend you save the packing box and materials, if possible, for equipment storage or possible future shipment.

1. Take the manipulator out of the box on a clean, dry, level surface.
2. **REMOVE THE SHIPPING CLAMP COMPLETELY!** Be sure to save it for later use.

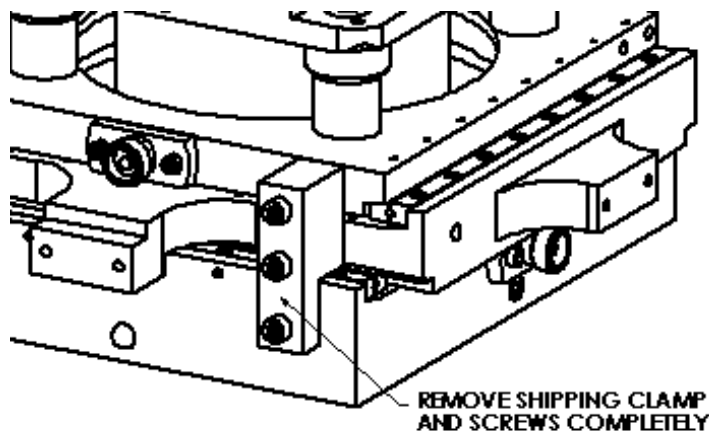

3. Install the Micrometers. We ship your unit with the micrometers removed to prevent damage. The screws for each micrometer are enclosed in a ziplock bag and packaged with the micrometers. Reassembly is a rather simple process. Insert the screws in the appropriate holes in the micrometer mount. Line up the screws and the micrometer load nut with the mating holes/part on the manipulator. Start the screws, but do not tighten. Next, thread the knurled micrometer nut onto the micrometer insertion bracket. Tighten only finger tight. Finish tightening the two screws. Repeat the process for the other micrometer.

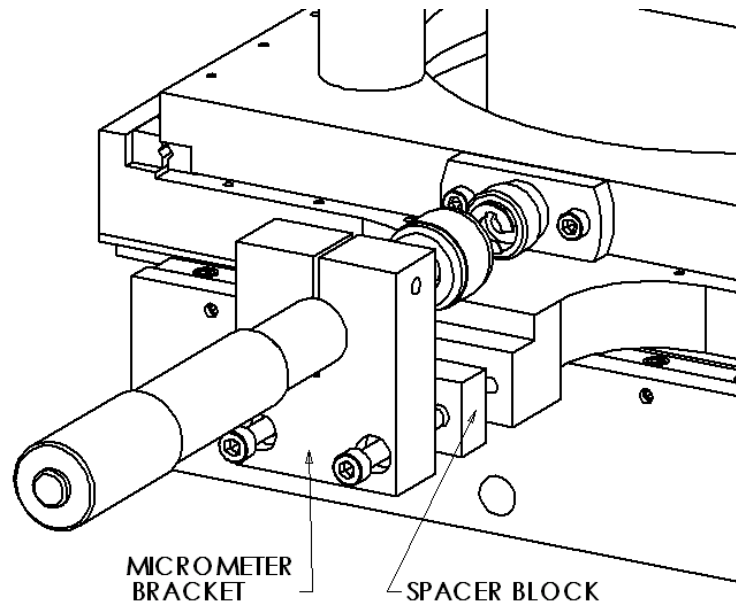

4. Remove the shipping covers and aluminum foil from the flanges. The manipulator is now ready for installation.

**General Precautions:**

Under normal conditions your manipulator will provide years of trouble-free service, especially if the following simple maintenance is performed. After several bakeouts, it may be necessary to relubricate the lead screw and/or micrometers. Use the grease in the supplied syringe. The micrometers can be removed for easier access. When replacing the screws in the micrometer brackets or any other location on the manipulator, be sure to re-coat the threads with an anti-seize compound.

1. Do not allow contamination to get into the bellows interior.
2. The stainless steel bellows is made from thin material and is fragile. Do not hit it or allow it to hit other objects.

3. Do not over-travel the unit. Hitting the side of the bellows may cause damage.

Use the appropriate bolts, nuts, washers and gasket to mount the manipulator to your chamber. The standard MC1500 / 2000-series manipulator uses the following bolt sizes:

Location	Nominal Flange Size	Bolts SAE (Metric) Sizes
Top flange (Standard tapped)	4.5" (114 mm) 6.0" (150 mm)	5/16-24 X 1-1/4 (M8 X 1.25 X 30) 5/16-24 X 1-1/2 (M8 X 1.25 X 35)
Bottom Flange (Standard non-tapped)	4.5" (114 mm) 6.0" (150 mm)	5/16-24 X 1.75 (M8 X 1.25 X 45) 5/16-24 X 2 (M8 X 1.25 X 50)

When tightening the flange bolts, make sure the bolt heads and threads are in good condition, the threads are lubricated with anti-seize material and that the wrench fits properly. Turn the bolts deliberately and with great care. A stripped, seized or broken bolt can be frustrating. A slipped wrench can puncture the bellows or cause bodily injury. Install the MC1500 / 2000-series manipulator on your chamber/flange as you would any other ConFlat type flange. Use standard, 0.080" thick, flat copper gaskets. The following tightening sequence for **lubricated bolts with washers** is recommended. First finger tighten all bolts evenly then sequentially torque the bolts in even steps.

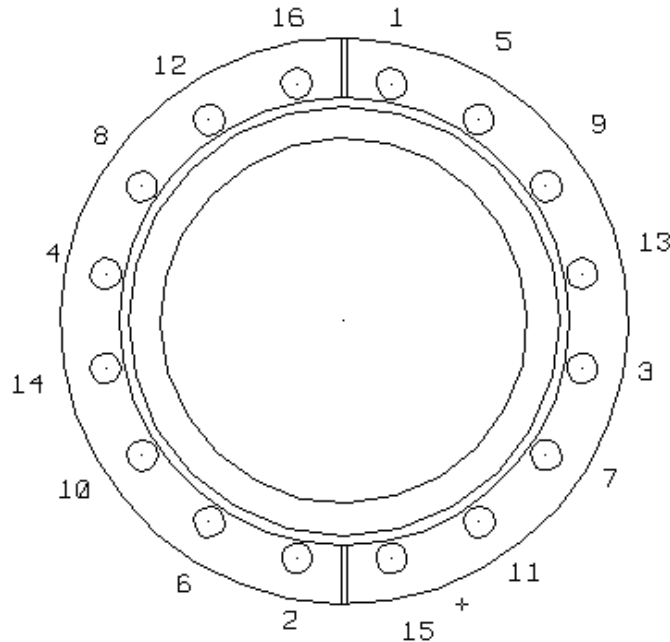

**Bakeout:**

Bakeout in normal fashion, but **NEVER** exceed 100<sup>0</sup>C with the micrometers attached during bakeout. Higher temperatures can damage the precision components. If the micrometers are removed, replace the shipping clamp and bakeout up to 200<sup>0</sup>C. Monitor the temperature during bakeout. Never translate the manipulator during bakeout or when it is above ambient temperature. Always remove any motor or limit switches before bakeout.

For 4.5-6" ConFlats - Maximum torque 120-150 in/lbs

### **X-Y gib adjustment:**

Lateral alignment of the X-Y slides is maintained by special crossed roller bearings made of hardened carbon steel. These bearings will corrode. Do not allow moisture to condense on or in the bearings. Do not allow LN<sub>2</sub> to chill the bearings. The X-Y slides have an adjustment for side play. This is set at the factory and *virtually never* needs readjustment. In the event readjustment is necessary, this function should only be performed by a technician experienced in such adjustments. Make sure the slide bearing faces are clean and free from debris. Remove the micrometer of the axis to be adjusted so the slide moves freely. This is important because the technician must be able to feel whether or not the slide is tight or binds. Next, slightly loosen the bolts that retain the slide *nearest* the gib adjustment screws. Then readjust the side play and retighten the screws in the slide. Make sure the crossed roller cage is centered between both ends when the slides are in the middle of their travel. Do not over tighten the screws.

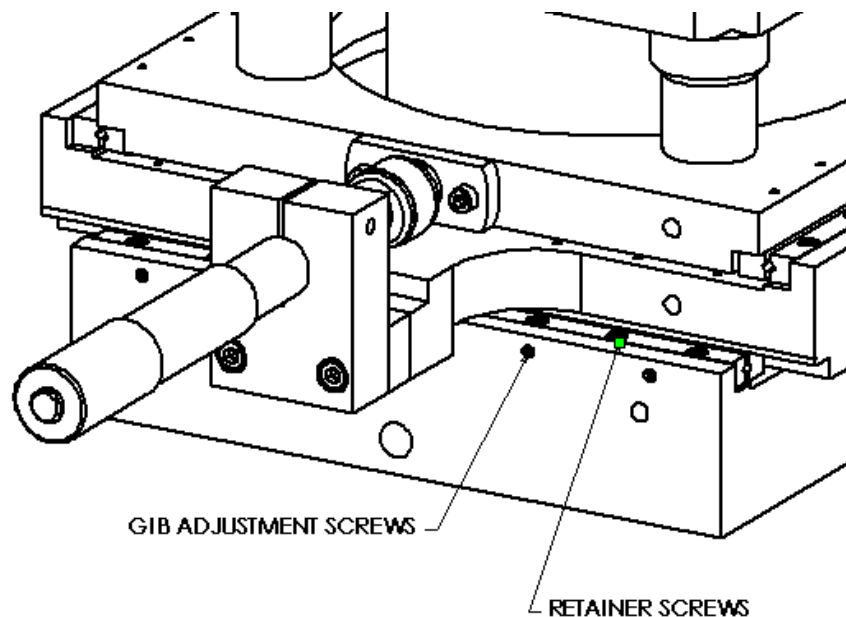

Gib Adjustment Figure

### **Non-tapped bottom flange:**

On specially-ordered manipulators, the bottom flange is non-tapped (non-threaded) to allow mounting devices with tapped bolt holes, such as gate valves. To mount such a device to the bottom flange of a MC1500 / 2000-series manipulator, vent the manipulator and remove it from the vacuum system. Next, remove the 4 screws that hold the flange ring on the top flange and the 4 screws that hold the bottom flange in the bottom frame. Remove the bellows. Install studs in the tapped mating flange, install a new gasket and couple the mating equipment to the bottom flange of the MC1500 / 2000. Install washers and nuts on the studs as they protrude up through the bottom flange. Ensure that the new equipment is aligned appropriately as the flange will not be rotatable after the bolts are tight. Support the equipment securely to withstand the torque of tightening the bolts and to protect the bellows. Reinsert the traveling flange and retainer ring on the top slide of the MB1500 / 2000.

**Motors:**

Stepper motors can easily be installed in the field. To install steppers on the X-Y axes, remove the micrometer bracket and the micrometer insertion bracket.

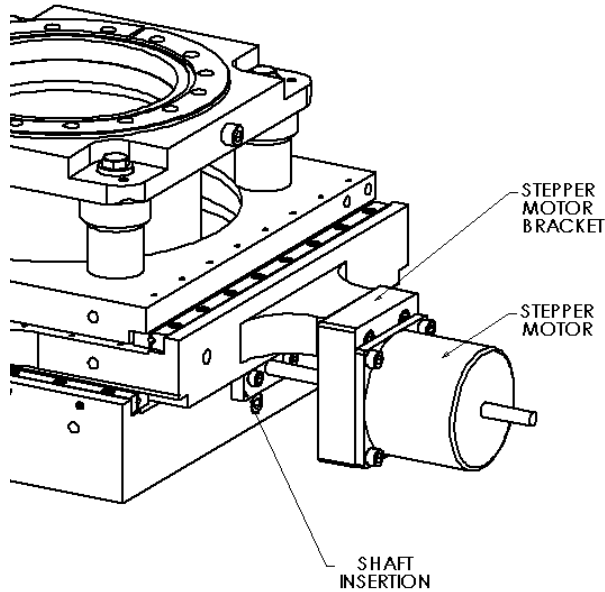

Replace them with the lead screw bracket and motor bracket, as shown in the above illustration.

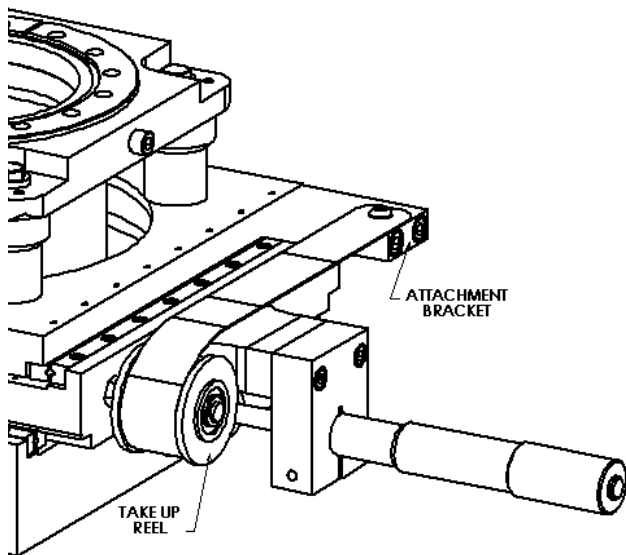

**Horizontal Mounting Kit:**

The Horizontal Mounting Kit is used when the manipulator must be mounted with the center axis horizontal (the flange faces are vertical). In this orientation, the load of the Y axis, the flange and any installed equipment are directly carried axially by the micrometer. This can easily exceed the rated end load for the micrometer as well as make it difficult to adjust. To compensate for this loading, a Horizontal Mounting Kit is factory installed on specially-ordered manipulators but can be retrofitted to any MC1500 / 2000-series

manipulator. The Horizontal Mounting Kit is uses specially-selected constant-force springs that counterbalance the anticipated load.

Note that these springs are quite strong and, if accidently is released at the wrong time, can easily injure fingers and hands, sometimes severely. Please use the supplied accessories and follow these simple guidelines whenever installing or removing the Horizontal Mount Kit.

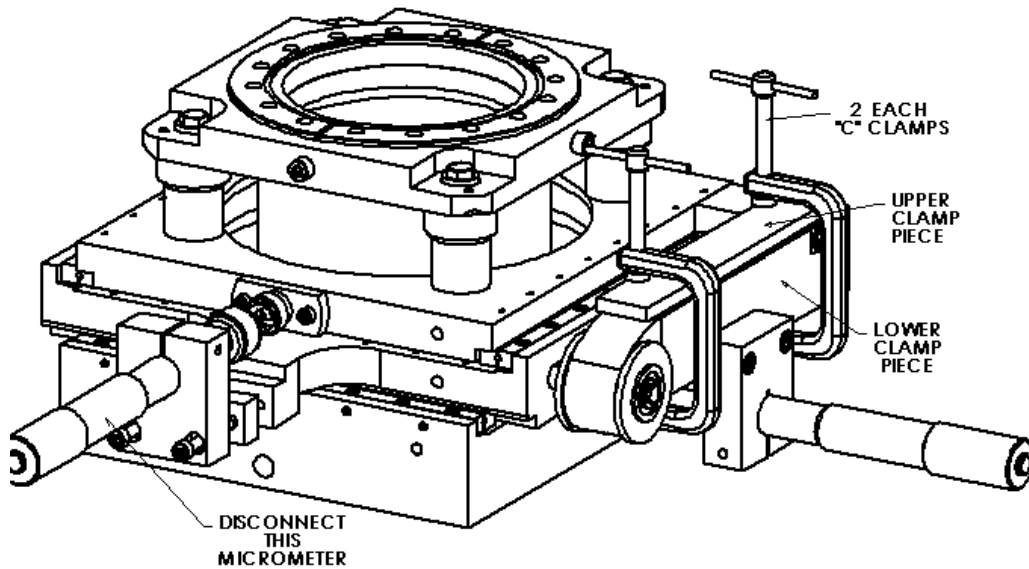

Included with each Horizontal Mount Kit are four 'C' clamps and two sets of Upper and Lower Clamp Pieces, anodized red for easy identification. To remove the Horizontal Mounting Kit, place the Upper and Lower Clamp pieces on either side of the constant force spring, as shown. Be sure the Lower Clamp Piece fits snugly against the Attachment Bracket. Tighten the two 'C' clamps on either side of the micrometer, as shown. Restrain the Y axis slide from falling due to gravity by loosely installing the shipping clamp. Next, disconnect the Y axis micrometer nut and retract the micrometer until it is clear of the insertion bracket. Finally, remove the two screws in the Attachment Bracket and unscrew the Take up Spool from the X Axis Slide. Be sure to leave the 'C' clamps in place during storage of the Horizontal Mounting Kit. To reinstall the Horizontal Mounting Kit, reverse the above procedure.

### **Adjusting the tilt of the top flange:**

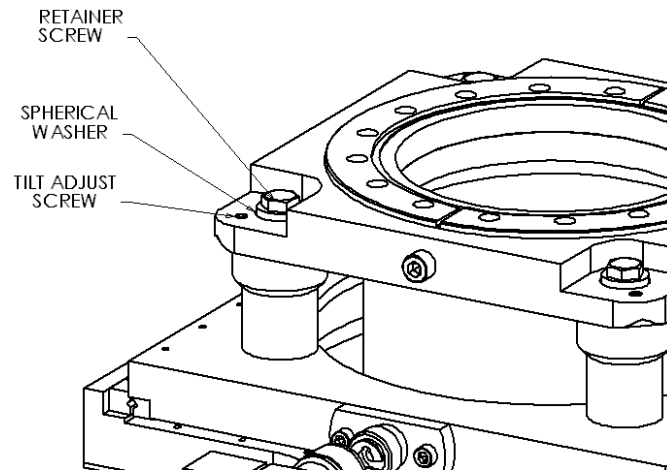

The top flange carries the ‘payload’ of whatever is mounted on it and also carries an atmospheric load of approximately 200 pounds /90 Kg for the MC20 series and 140 pounds / 65 Kg for the MC15 series. This flange can be adjusted up to  $\pm 2^\circ$  to compensate for any slight misalignment of chamber flanges or installed devices. Each corner of the flange ring contains two screws. The larger Retainer Screws have a spherical washer and are used to clamp the flange ring to the slide even when at an angle. After loosening the Retainer screws slightly, the smaller Tilt Adjustment screws can be adjusted to realign the top flange to the desired orientation. This realignment can be done while the manipulator is under vacuum. Be sure to re-tighten the Retainer screws in the flange ring afterwards.

### **Lubrication:**

Under normal conditions, your manipulator will provide years of trouble-free service. As delivered, the micrometers and XY slides are lubricated with high temperature grease. Re-lubricate every third or fourth bake out with the grease provided. Do not use a hydrocarbon grease such as Felpro C100™ for bearings or lead screws that will be baked because the hydrocarbon greases will cake and dry out. After several bake outs, it also may be necessary to re-lubricate the bearings within the knurled micrometer nuts. Use the grease in the supplied syringe. A small amount is sufficient.

We have operated your unit prior to shipment to assure that it works properly. Prior to calling the factory, check to make certain you have removed all shipping constraints, have read these instructions, and have checked for shipping damage. If you decide to call the factory for support, it is best to have the manipulator close to the phone, for ease of description.

### **Packaging for storage or reshipment:**

The bellows on your unit is particularly susceptible to damage/contamination. Normal precautions for shipment are, therefore, usually inadequate. Please follow these guidelines:



1. Work on a clean surface when packaging.
2. Place aluminum foil over the bellows openings, then re-install the shipping covers. Do not allow any contamination to get into the bellows interior.
3. Remove the micrometers. Place the screws in a bag. Wrap the micrometers and the bag in bubble pack.
4. Re-install the shipping clamp screw.
5. Place the unit in a polyethylene bag.
6. Place the lower piece of foam-in-place packaging in the box (check the condition of the box and replace as necessary). Place the unit into the foam as indicated by the outline in the foam. Now place the micrometers into the box as indicated. Place the upper piece of foam-in-place packaging over the unit as indicated by the outline in it. Secure the box shut, and the manipulator is ready to ship or store.

**Accessories included:**

1. Hex wrench kit
2. Lubrication kit

**Parts and factory service:**

Replacement parts and non-warranty factory service are available on a fast turnaround basis. Please consult the factory with your specific need.

End